

# *ThetaMount Pressure Cold Machine*

MOUNTING



2023

04 / 15

# ThetaMount Pressure Cold Machine

ThetaMount pressure cold mounting machine is designed with compact pressure technology with maximum pressure as high as 2bar, which can ensure that the specimen does not contain bubbles after mounting while the physical and chemical properties of the resin & mounting agent will not change. So it can be used for rapid mounting of all cold mounting resins (especially for TJ-2210 acrylic resin) and make high-quality specimen.



## Features:

- ◆ Compact pressure technology design, pressure can be increased fast;
- ◆ Specimen does not contain bubbles after curing;
- ◆ Won't influence the physical and chemical properties of the resin & curing agent;
- ◆ No unpleasant smells during curing;
- ◆ Much efficient and good quality in sample preparation.

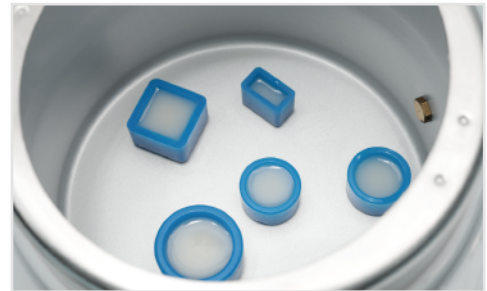

## Technical Specifications:

Model	ThetaMount
Operating Pressure	2.0bar
Safety Valve Overflow Pressure	2.8~3.3bar
Chamber Diameter	Φ235×170mm
Dimension (W×D×H)	308×415×289mm (Close) 308×415×342mm(Open)
Weight	8.5kg

## Control Panel Introduction:



- ① Pressure gauge      ② Timer      ③ Pressure Increase/Release

## Related Consumables & Accessories:

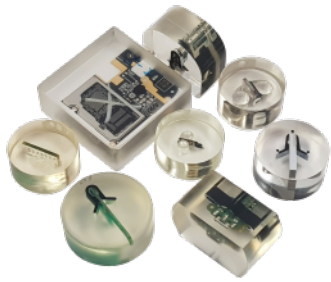

Cold Mounting System



Silicone Mold Cups



Sample Support Clip

## Dimension Figure

Unite: mm

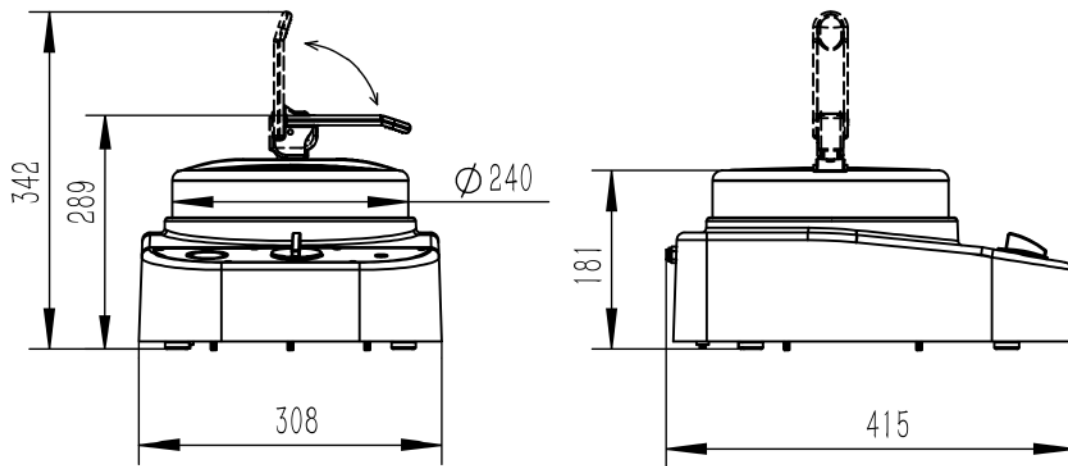

## Technical Specifications:

1	Serial number		Φ6mm PU pipe (With quick plug connector)	1PC
2	Power cord		220V, 10A, 1.5M	1PC

## Optional accessories:

1	Air Compressor		220V, 1.1kW, Exhaust pressure 0.8MPa, capacity 40L	1PC
---	----------------	---	--	-----

## Purchase list:

### Cold Mounting System:

02.03.411/421	TJ 2210A Acrylic Resin (General type)	1kg/2.5kg
02.03.412/423	TJ 2210B Curing agent	800ml/2000ml
02.03.461/471	TJ 2211A Acrylic cold mounting resin (Fruity model)	1kg/2.5kg
02.03.462/473	TJ 2211B Curing agent	800ml/2000ml
02.04.871	TJ 2228A Epoxy Slow	2kg
02.04.872	TJ 2228B Curing agent	1kg
02.04.721	TJ 2221A Epoxy King	2kg
02.04.722	TJ 2221B Curing agent	1kg

### Sample Support Clip:

07.01.010/012	Plastic Coil Clip,6*100mm	100pcs/1000pcs
07.01.016/017	Stainless Steel Clip,7*120mm	100pcs/1000pcs
07.04.010/012	T Black Plastic Clip,10*9*13mm	100pcs/500pcs
07.03.010	T White Plastic Clip,10*9*13mm	100pcs
07.05.001	S Black Plastic Clip,20*10*8mm	100pcs

### Mounting Cups:

2-Part Mounting Cups (Separate Firm Molds)	08.02.002	Φ25*20mm	10pcs
	08.02.004	Φ30*23mm	
	08.02.006	Φ32*25mm	
	08.02.008	Φ40*27mm	
Silicone Mold Cups (Silicone)	08.02.018	Φ20*18mm(depth)	10pcs
	08.02.020	Φ25*18mm(depth)	
	08.02.022	Φ30*18mm(depth)	
	08.02.030-1	Φ40*25mm(depth)	
	08.02.050	50*70*20mm(rectangle)	
08.02.058	180*106*30mm(rectangle)		
Teflon Mold Cups (Teflon,easy release)	08.02.110	Φ25	1pc
	08.02.120	Φ30	
	08.02.132	Φ40	



TROJAN (SUZHOU) MATERIAL TECHNOLOGY CO.,LTD

Tel: +86-512-65283666

Email: sales@trojanchina.com

Web: www.trojanworld.com

Add: Building 26, No.228 Gongtang Road, Luzhi Town, Wuzhong Suzhou, China

